

Multi metal oxide sensors system for some chemical functional group classification: The study through pattern classifier using correlation model in Electronic Nose Technology

Wasu Phanphaisarn

Faculty of Science and Technology, Pibulsongkram Rajabhat University,
Phitsanulok 65000, Thailand.

Corresponding author, E-mail: wasu_phy@hotmail.com

ABSTRACT

Four metal oxide sensors commercially available namely MQ2, MQ3, MQ6 and MQ8 were used as array sensors to specify methanol, ethanol, acetone and acetaldehyde. The voltage divider circuit was created to archive voltage signal with $10k\Omega$ ($\pm 5\%$) reference resistor. Four-channel signal analyzer was carried out using ATMEGA328p microprocessor. An internal 10-bit ADC was programming with BASCOMAVR compiler to archive digital chart recorder. The signal was then digitalized and recorded using Microsoft Visual Basic™ via a serial interface at baud 19200 bps, 8 data bit, 1 stop bit and none parity with the sampling rate of 1 sample per second on four channels simultaneously couple with graphical plots on four different sensor elements. A reaction chamber with small DC diaphragm dispensing pump was designed to archive gas array sensor detection system. Four aliquots of each volatile (100%, 50%, 25%, 12.5% v/v) were diluted by distilled water and the head space was aspirated into the reaction chamber using 50mL disposable syringes. The injection volume to the chamber was optimized to 30 mL. The recorded signals were analyzed using correlation model. The purposed system was accurately specifying each volatile organic with the correlation factor of similarity > 0.995 with accuracy less than 5% RSD. The sampling rate of speciation each volatile was 15 samples per hour.

Key words: Metal oxide sensor, Correlation model, Volatile organic

INTRODUCTION

Advance in electronic chemical sensors compromised with powerful personal computer yield a capable of complex and simple odor recognition. (P.I. Neaves *et al.*, 1995, C.D. Natale *et al.*, 1996, T. Dymerski *et al.*, 2014). Classes of electronic sensors were divided based on their physical changes e.g. chemoresistor, thermal, pellistor, acoustic/piezo, potentiometric/amperometric, optical and many other properties (M.A. Craven *et al.*, 1996). Oxide materials are available in electronic market as a low cost device which are sensitive to combustible gases with chemoresistor properties. (A. Loutfi *et al.*, 2015) These devices are operated with high temperature (300 to 450 centigrade) that show chemisorbed properties where pseudo-combustion takes place resulting in change of its electrical conductivity. (K. Yana *et al.*, 2015, A. Berna *et al.*, 2010, B.A. Snopok *et al.*, 2002).

Catalytic metals were synthesized to metal oxides and doped or coated with trace transition elements to archive core of chemoresistors(S. Kiani *et al.*, 2016)The powder of desired catalytic metal oxides is then press in to a rod sized in millimeters with the compression molding. Then the micro nickel-chromium heating filament is inserting into the hollow rod at the middle to heat up the device to operate at an elevated desire temperature. (Z. Hu *et al.*, 2016) Most commercial sensors available in the market were investigated to be rod type. Few of them are in thick and thin film types that give high resistivity and less change when operate in divider circuit.

The propagation of odor was designed variously due to the interaction between gases phase of analyte and solid phase of sensors. The interaction between analyte and sensor is based on gas to solid partition which relies on seven parameters list below:

- (1) the flow delivery system that carries the odor from the source to the sensor array, e.g., the flow profile and type of carrier gas;
- (2) the nature of the odour, e.g.,type, concentration;
- (3) the reaction kinetics of the odour and the active material;
- (4) the diffusion of the odour within the active material;
- (5) the nature of the sensing material, e.g., physical structure, porosity, thermal time-constant;
- (6) the nature of the substrate supporting the active material,e.g.,thermal conductivity, acoustic impedance;
- (7) ambient conditions, e.g., temperature of active material, carrier gas, humidity, pressure.

Many propagations of analyte to sensors array were designed to meet the specific shape of a reaction chamber. Most of which is the mixed carrier gas with the desire amount of analyte in the manifold using mass flow controller. The static amount of analyte in carrier yields rise and fall in signal based on seven parameters described above. Mass flow system was very popular in single device test but give no result in interaction between attack and decay of each sensor in array. Flow injection method were substitute to carry out how fast chemisorbed properties were take place at the surface of chemoresistor devices. The aspiration of air carrier inside the chamber by suction pump was design to propel gas through sensors array. With the specific interaction between each sensor in array, a prediction model was gained as pattern recognition. Most of which was principle component analysis (PCA) and K-mean values prediction yielding a set of descriptor (k-class) that construct pattern-recognition (PARC) engine. The classic PARC engine used a radar plot of sensors to identify odor from discrimination of the responses.

The purposed method was using correlation of the whole interaction between attack and decay of analyte gas through sensors array resulting in specific peak shape in each chemoresistor device. From the interaction profiles,

the identity of some chemical functional group was classified using their identity correlation.

MATERIALS AND METHODS

Design of gas flow injection system

An acrylic box sized 55x75x45 mm (Figure 1) was used as a reaction chamber. A Teflon® tubing was used to carry gas from the chamber to a pump. A 5VDC diaphragm suction pump was connected to the chamber via a Teflon® tubing. A pump was then controlled with a relay I/O board which triggered by ATMEGA328p microprocessor.

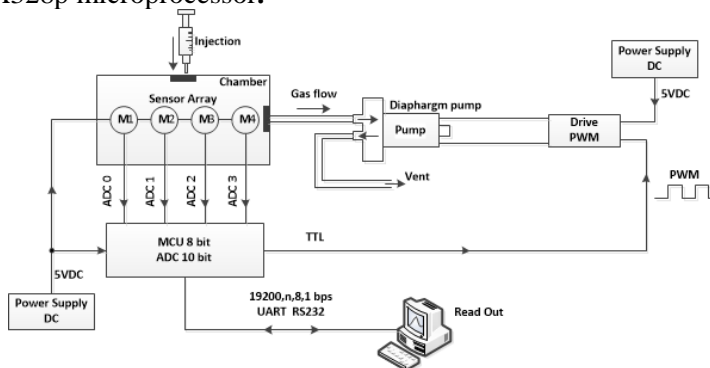

Figure 1 Gas flow injection system

Design of circuit

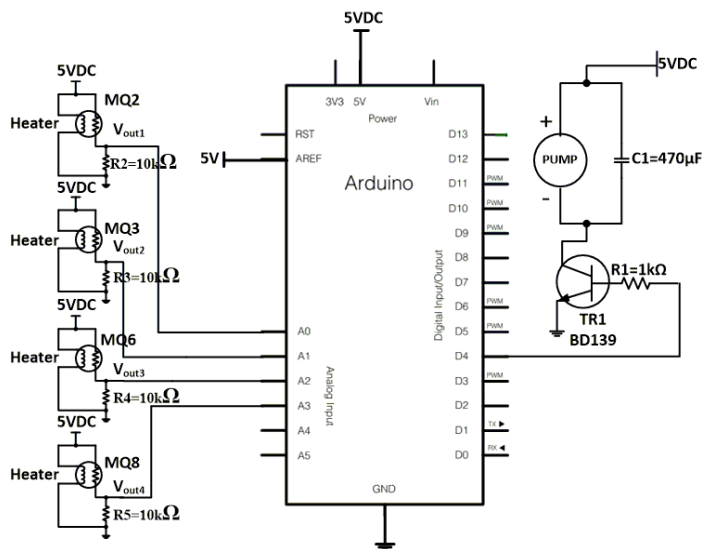

Figure 2 Circuit diagram.

ATMEGA328p microprocessor was run at 16 MHz with crystal resonator. Five volts TTL level were used in the system to trigger all I/O devices. A BD139 (TR1) was drive with control signal from the microprocessor. A 1 kΩ resistor (R1) was limit the driving current from microprocessor to trigger TR1 emitting current to a suction pump motor which auxiliary supply by external 5VDC power.

Main primary noise suppressor was designed from the power supply circuit. A 470 μF capacitor (C1) was used to collect a residue charge of fluctuation during measuring of signal. Four commercial chemoresistor devices (MQ2, MQ3, MQ6 and MQ8) were connected with static 10 kΩ voltage divider resistors (R2, R3, R4, R5) and the output were connected directly to analog to digital (ADC) of the microprocessor through port A0 to A3 without filter.

Design of microprocessor routine

The pseudo code of the microprocessor routine is as list below:

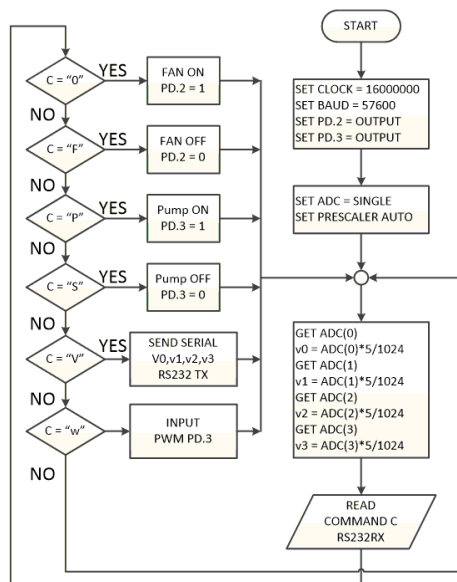

Figure 3 The prototype of proposed system

Design of personal computer routine

The NTGraph activeX control was used to display plots of sensor elements. Each session in an interval of one second, the PC transmitted ASCII “V” to the microprocessor. Microprocessor responses with a data stream with comma delimited for each field of voltage reading from sensors. The numeric values were then plotted and saved to files for later digital processing were modeled.

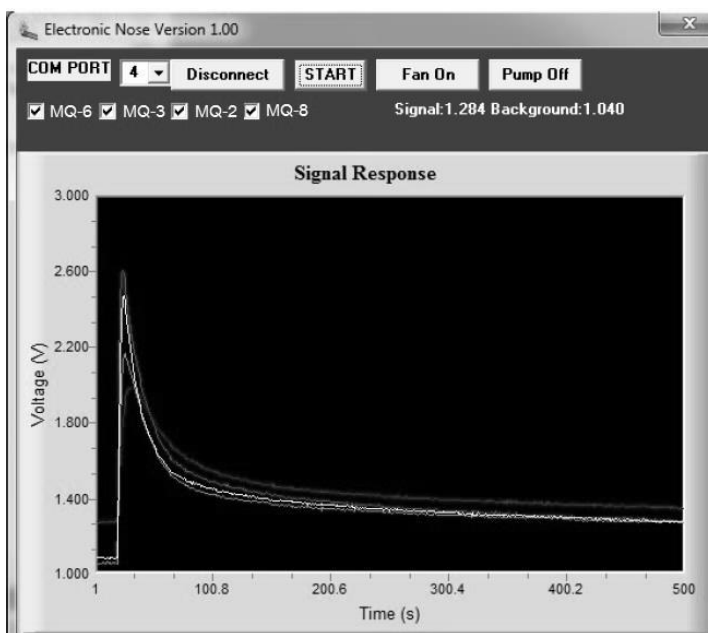

Figure 4 Application Interface

Preparation of chemical odor

Methanol, ethanol, acetone and acetaldehyde were retrieved from Sigma-Aldrich with 99.9% analytical grade to be act on behalf of hydroxyl group (ethanol and methanol), carbonyl group (acetone) and carboxaldehyde group (acetaldehyde). An aliquot of half series dilution by volume with double distilled water were applied to 100 mL volumetric flasks. The series concentration of each chemical odor (100, 50, 25, 12.5% v/v) were then transferred to septum conical flasks which a headspace vapor can be carried out by 50 mL disposable syringes into the chemoresistors array. The manifold of the gas flow system is as shown in figure 1.

RESULTS

Signal response

From the experiment, when aspirate the headspace (100% to 12.5% v/v) of each chemical odor (methanol, ethanol, acetone and acetaldehyde), the signal responses were as shown in figure 5a,5b,5c and 5d respectively.

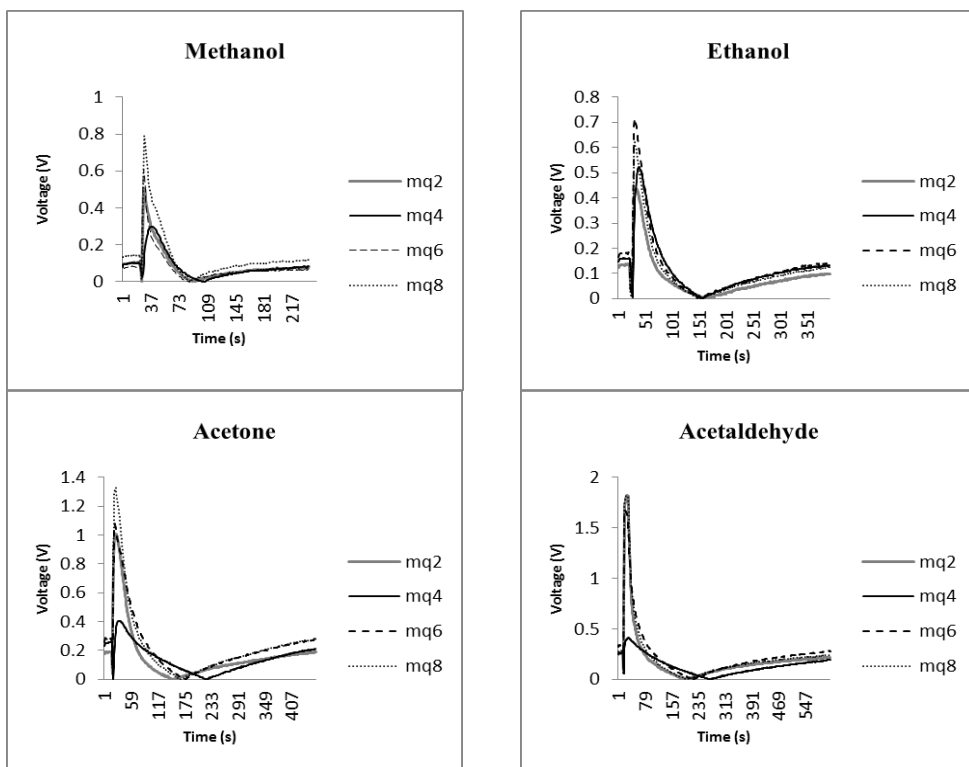
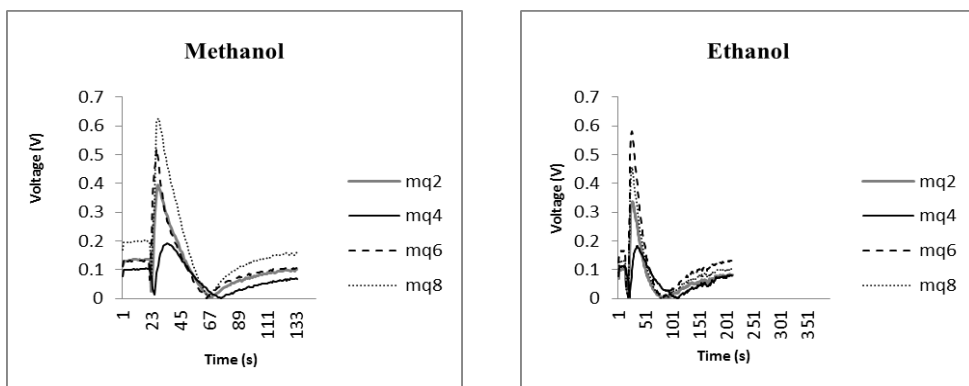

Figure 5a Signal responses form 100% v/v ethanol headspace 50mL



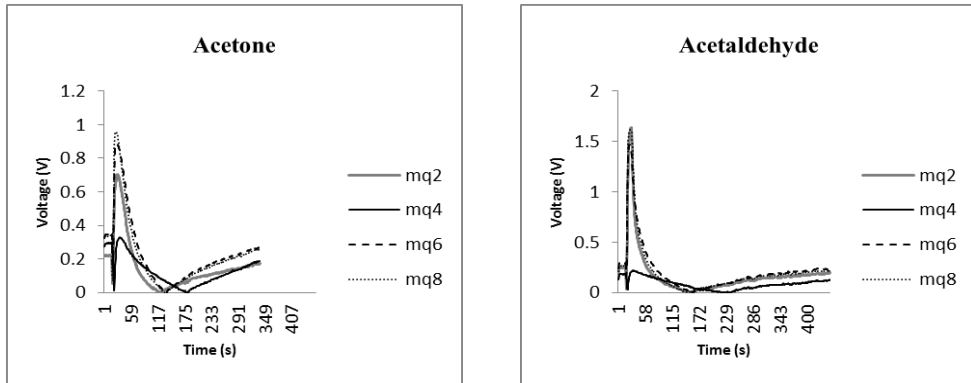

Figure 5b Signal responses form 50% v/v methanol headspace 50mL

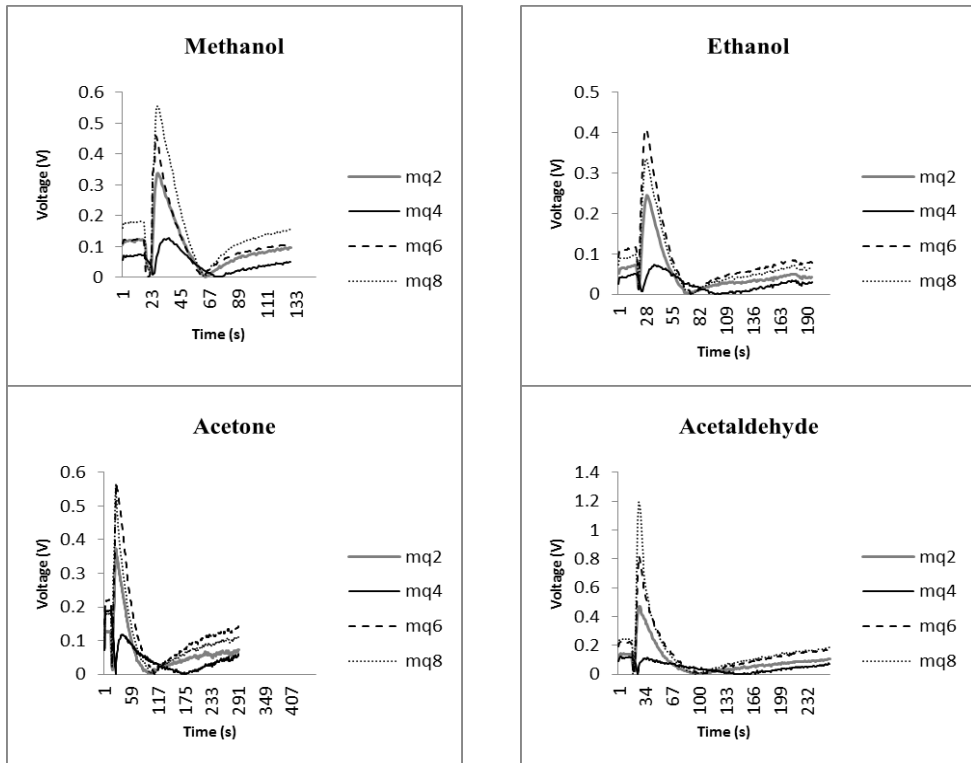

Figure 5c Signal responses form 25% v/v acetone headspace 50mL

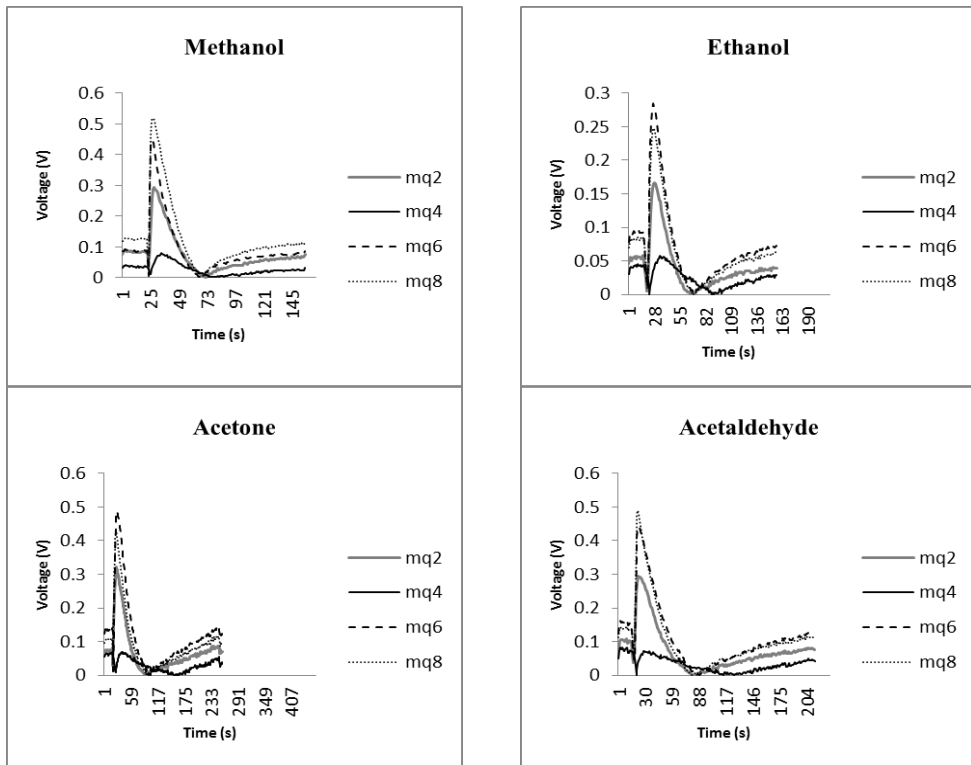

Figure 5d Signal responses form 12.5% v/v acetaldehyde headspace 50mL

Implementing a model

In this case, the correlation value from the unknown to model was calculated from datapoints with the equation show in Equation 1. The cross correlation in Table 1.

$$r = \frac{\sum_{i=0}^N (X_i - \bar{X})(Y_i - \bar{Y})}{\sqrt{\sum_{i=0}^N (X_i - \bar{X})^2 \sum_{i=0}^N (Y_i - \bar{Y})^2}} \tag{1}$$

Where

- r = correlation coefficient (as similarity)
- X_i = time datapoints
- Y_i = sensor response (in voltage) datapoint
- \bar{X} = average in X
- \bar{Y} = average in Y

Table 1 Cross correlation of the reference model versus unknown suspected

Reference	Unknown suspected			
	(Ethanol)	(Methanol)	(Acetone)	(Acetaldehyde)
Ethanol	<u>0.991899</u>	0.887401	0.881939	0.794526
Methanol	0.896295	<u>0.970813</u>	0.788602	0.680701
Acetone	0.892799	0.803438	<u>0.992428</u>	0.938757
Acetaldehyde	0.790778	0.665180	0.950760	<u>0.995375</u>

Decision value

From the cross correlation, the model shows the separation value of 0.96 in five replication of injections. The correlation value below 0.96 was rejected as the confidential level did not meet the decision criteria. The correlation value higher than 0.96 was accepted to be match with the existing model in the databank. Partial match and alternative match were then calculated from the mixture of the peak profile when applied mixture of complex odor.

DISCUSSION

Peak Characteristic

Each injection of volatile gives characteristic of signal response to each sensor resulting from pseudo combustive effect on each metal oxide layer. All of sensors are fabricated in hollow tube where heating filament of Ni-Cr microwire is inserted. Silica-alumina is used as a substrate to form a tube where Tin-oxide (SnO₂) are coated at the surface. Impurities in part per million of Cadmium(Cd), Zinc(Zn), Lead(Pb) and Tungsten(W) are doped in composition to form quasi lattice substitution in SnO₂ where selectivity and characteristic of sensors are shown.

MQ2 is a cadmium-doped Tin-Oxide sensor which senses to combustible gas that contains C-H and H-H chain in molecules. MQ3 is a zinc-doped Tin-Oxide sensor which senses to alcohol that contains C-O chain in molecules. MQ6 is lead-doped Tin-oxide sensor which senses to combustible gas but gives small sensitivity to alcohol and smoke due to semi-metal element defect in lattice (Pb). MQ8 is highly sensed to hydrogen with H-H bond but gives small sensitivity to alcohol due to tungsten substitution in the SnO₂ lattice defect.

All sensors need thermal energy to activate quasi combustible properties. Exposing sensors in water and freezing are caused its lose sensitivity. Initial state of heating stabilizes sensors to get rid of bound water where conductivity drift up rapidly to the stable state. Temperature and humidity also affected the sensitivity

of each sensor as it required thermal energy to activate pseudo combustion and eliminating of bound water inside the lattice.

Arriving and decay

When vapor reach sensors, it attached to the surface to form quasi combustion. Each gas arrive sensors and attack the surface giving rapid increasing of the signal due to electronic transfer between surface of counter electrodes until it reaches top of peak. After that, each gas has completely reacted and combusted at the surface and slowly decays from the surface yielding the signal falls from the peak to the baseline. Statistical distribution of data points from sensors are then obtained and used as the model to construct the cross correlation between unknown and recorded profiles.

Peak interpretation

Variation in vapor concentration head space injection yields variation in time of arriving and decay. Normalization in time domain is not persuaded due to patching of data points. Half-width interpretation is used instead of time normalization. Half-width interpretation also gives satisfactory results with good speciation, accuracy and precision. Each signal from peak is trimmed at half-width of peak. The data points of this zone are interpreted instead of the whole injection from start to peak and from peak to baseline.

Averaging of correlation

Data points from half-width peak from each sensor were trimmed and used as a library of model. Four averages cross correlation between signal of unknown (MQ2, MQ3, MQ6 and MQ8) and known library are averaged resulting in identification of each vapor with correlation factor of similarity. The correlation matching was performed by software to identify the type of vapor. Mixture of vapor was not performed as the similarity of -OH group in methanol and ethanol and C=O group in acetone and aldehyde may interfere the correlation similarity with related to cross correlation errors.

CONCLUSION

The purposed method was successfully identified methanol, ethanol, acetone and acetaldehyde from various concentrations with the correlation factor of similarity > 0.995 and the accuracy less than 5% RSD. Speciation of each volatile was carried out successfully with satisfactory results.

ACKNOWLEDGEMENTS

The authors would like to thank following organization for facilities supported:

- Department of Chemistry, Faculty of Science, Chiang Mai University
- Graduate School, Chiang Mai University
- Department of Physics, Pibulsongkram Rajabhat University

REFERENCES

- P.I. Neaves, J.V. Hatfield. (1995). A new generation of integrated electronic noses. *Sensors and Actuators B*, 26-27,223-231.
- C.D. Natale, A.M. Fabrizio, A. D' Amico, P. Nelli, S. Groppelli, G. Sberveglieri. (1996). An electronic nose for the recognition of the vineyard of a red wine. *Sensors and Actuators B*, (33),83-88.
- T. Dymerski, J. Gebicki, W. Wardencki and J. Namiesnik. (2014). Application of an Electronic Nose Instrument to Fast Classification of Polish Honey Types. *Sensors*, (14), 10709-10724.
- A.D. Wilson, M. Baietto. (2009). Applications and Advances in Electronic-Nose Technologies. *Sensors* (9), 5099-5148.
- P. Suna, X. Zhoua, C. Wangb, B. Wangb, X. Xua, G. Lua. (2014). One-step synthesis and gas sensing properties of hierarchical Cd-doped SnO₂ nanostructures. *Sensors and Actuators B*, (190),32– 39.
- Z. Shi, T. Yu, Q. Zhao, Y. Li, Y. Lan. (2008). Comparison of Algorithms for an Electronic Nose in Identifying Liquors, *J. Bionic Engineering*, (5), 253–257.
- M.A. Craven, J.W. Gardner. (1996). Electronic noses - development and future prospects. *Trends in analytical chemistry*. (15), 486-493.
- A. Loutfi, S. Coradeschi, G.K. Mani, P. Shankar, J.B. Balaguru Rayappan. (2015). Electronic noses for food quality: A review. *J. Food Engineering*, (144),103–111.
- K. Yana, D. Zhang. (2015). Improving the transfer ability of prediction models for electronic noses. *Sensors and Actuators B*, (220),115–124.
- A. Berna. (2010). Metal Oxide Sensors for Electronic Noses and Their Application to Food Analysis, *Sensors*, (10), 3882-3910.
- B.A. Snopok, I.V. Kruglenko. (2002). Multisensor systems for chemical analysis: state-of-the-art in Electronic Nose technology and new trends in machine olfaction. *Thin Solid Films*, (418), 21–41.
- J.W. Gardner, P.N. Bartlett. (1996). Performance definition and standardization of electronic noses, *Sensors and Actuators B*, (33),60-67.
- R. Miiller. (1991). High electronic selectivity obtainable with nonselective chemosensors. *Sensors and Actuators B*, (4),35-39.
- S. Kiani, S. Minaei, M.G. Varnamkhasi. (2016). A portable electronic nose as an expert system for aroma-based classification of saffron. *Chemometrics and Intelligent Laboratory Systems*, (156),148–156.
- Z. Hu, X. Li, H. Wang, C. Niu, Y. Yuan, T. Yue. (2016). A novel method to quantify the activity of alcohol acetyltransferase Using a SnO₂-based sensor of electronic nose. *Food Chem*, (203),498–504.

- R. Gutierrez-Osuna, H.T. Nagle, S.S. Schiffman. (1999). Transient response analysis of an electronic nose using multi-exponential models. *Sensors and Actuators B*, (61),170–182.
- J.W. Gardner. (1994). A Brief History of Electronic Noses. *Sensors and Actuators B*, 18-19,211-220.
- D.G. Gardner, J.C. Gardner, G.L. Laush, W.W. Meinke. (1959). Method for the analysis of multicomponent exponential decay curves, *J. Chem. Phys.*, (31),978–986.
- C. Di Natale, S. Marco, F. Davide, A. D'Amico. (1995). Sensor-array calibration time reduction by dynamic modeling. *Sens. Actuators B*, 24–25, 578–583.