

## **Experimental study of a thermoelectric solar collector integrated with a water lens**

Likhit Khamlarpao<sup>1</sup>, Jindaporn Jamradloedluk<sup>1</sup> and Charoenporn Lertsatitthanakorn<sup>2\*</sup>

<sup>1</sup> Post-Harvest and Agricultural Machinery Engineering Research Unit, Faculty of Engineering, Mahasarakham University, Kantarawichai, Maha Sarakham 44150, Thailand

<sup>2</sup> Energy Technology Division, School of Energy, Environment and Materials, King Mongkut's University of Technology Thonburi, Bangmod, Thungkru, Bangkok 10140, Thailand

\*Corresponding author. E-mail: freeconvect@hotmail.com

### **ABSTRACT**

In this paper the results of the influence of a water lens concentrator on the performance of a thermoelectric (TE) solar collector are presented. The proposed TE solar collector with water lens concentrator was composed of an absorber plate, TE modules, a rectangular fin heat sink and a water lens. The water lens concentrator was placed above the TE solar collector. The water lens concentrator was installed on a one-axis sun-tracking system to obtain high solar radiation. Concentrated solar radiation from the water lens heats up the absorber plate so that a temperature difference is created across the TE modules to generate a direct current. Only a small part of the absorber solar radiation is converted to electricity, while the rest increases the temperature of the absorber plate. Improvement to electrical power output of the system can be achieved by the use of the water lens concentrator and TE technology. It was found that the optimum position of the focus length is 12 cm, which gives significantly higher electrical power output compared with the TE solar collector without the water lens concentrator.

*Keywords:* Thermoelectric, Electrical power, Water lens

### **INTRODUCTION**

Solar energy is an environment-friendly resource that has been utilized since antiquity. However, solar energy is difficult to use for heating energy storage media such as water or to generate electricity from thermal radiation. These difficulties arise principally because solar energy is highly dispersed. In order to solve this problem, various solar concentrators have been developed in the form of convex lenses and parabolic mirrors. The optimal design of these lenses and mirrors is indispensable for more effective utilization of solar power. The cost of the lenses may be expensive. Therefore, this study is to introduce a new type of lens concentrator. The lens concentrator is called a water lens. The water lens is composed of two parts: plastic sheet and water. The cost of water lens concentrator must be cheaper than other lens arrangements, and it must be easy to build.

Thermoelectric (TE) power generators convert heat energy directly to electricity. They have the advantage of being able to operate from a low or high grade heat source. This is a significant advantage because it makes them suitable for converting waste heat into electricity and for harnessing electricity from the sun (Rowe, 1999). A TE power generator is a unique environment friendly solid state energy

generator that has no moving parts and is very reliable. It consists of n and p semiconductors connected electrically in series and thermally in parallel. A source of heat is supplied at one end of the TE, while the other end is maintained at a lower temperature with a heat sink. As a result of the temperature difference, current flows through an external load resistance. The TE has low conversion efficiency. The low conversion efficiency has been a major limiting factor in their application as an electrical power generator. It also has restricted their use to specialized situations where reliability is a major consideration (Min and Rowe, 2002). This is not surprising though, because the TE generator is a thermal device that operates between two temperature regimes; therefore, the Carnot efficiency limits its absolute energy conversion efficiency. There are several parameters that affect the power output and conversion efficiency of TE power generation, and they have been studied by many researchers (Rinalde et al., 2010; Qiu et al., 2011; Zhe et al. 2011). Among these parameters, the figure of merit of TE materials and the temperature difference across the TE device have the greatest effect on power output. However, the figure of merit of the TE material is beyond the scope of this study. Solar TE generators convert a few percent of the entire incoming solar radiation into electricity. More than 90% of the incident solar radiation on a TE is reflected or converted to thermal energy. In order to increase the electrical and thermal output of the TE solar collector, reflectors are used to concentrate the solar radiation to the surface of the collector. A few research works reported on a TE generator with a solar concentrating collector. As an example, Fan et al.(2011). investigated a parabolic dish concentrator TE generator. A parabolic dish collector with an aperture of 1.8 m was used to concentrate sunlight onto a copper absorber plate. Four BiTe-base TE modules were used to convert the concentrated solar thermal energy directly into electric energy. A water cooled heat sink was used to remove waste heat from the cold side of the TE modules. Experimental results showed that the concentrator TE generator was able to produce electric power of up to 5.9 W for a 35°C temperature difference with a hot side temperature of 68°C. Lertsatitthanakorn et al.(2012). studied a double-pass TE solar air collector with flat plate reflectors. The flat plate reflectors were used to concentrate solar radiation onto the TE solar air collector. Experimental results showed that the optimum position of the reflectors was 60°, which gave significantly higher thermal energy and electrical power output than the TE solar collector without reflectors. This article presents the performance of a solar parabolic concentrator coupled to a TE module. The effects of air cooling, flow rate and fan orientation are investigated.

The aim of this paper is to study the electrical performance of the TE solar collector with a water lens concentrator for the climate of Maha Sarakham, Thailand.

**SYSTEM DESCRIPTION**

In order to investigate and compare the performance of the TE solar collector, two identical TE solar collectors were built. One was mounted on a fixed position base, and without a water lens. The other was integrated with water lens and mounted on a one-axis tracking base. A schematic view of the TE solar collector with water lens is shown in Fig. 1. The TE solar collector was composed of galvanized iron plate and the TE modules. A rectangular fin heat sink used on the cold side was made of aluminum. The space between the TE modules, absorber and heat sink was insulated using a closed cell elastomeric thermal insulator (thermal conductivity = 0.039 W/mK). The collector was 6 cm wide, 7 cm long. The absorbing surface in the collector was made of galvanized iron, 0.5 mm thick, painted with dull black. Two miniature TE modules (model EP3-06E046TRO, Aisin Seiki Ltd., Japan) made of bismuth telluride based alloys were used. Each module had an area of 8.3 x 8.3 mm<sup>2</sup> and 2.4 mm thick. The TE modules were connected in series. The fins were 0.12 cm thick, 6 cm long and had the height of 1.3 cm from the base. There were 17 fins with a pitch of 2.95 mm on the base. A fan was used to blow the air through the rectangular fin heat sink. In this study, the air flow rate was fixed at 0.065 m<sup>3</sup>/min. The water lens was made of two plastic sheets. One of the sheets thermoformed into a hemisphere shape and was used as a lens. The lens diameter was 21 cm. The other one was used as a cover plate on the lens. The cover plate was used to protect the water from spilling when the water lens tracked the sun. 0.734 kg of water was poured in the lens as shown in Fig. 1.

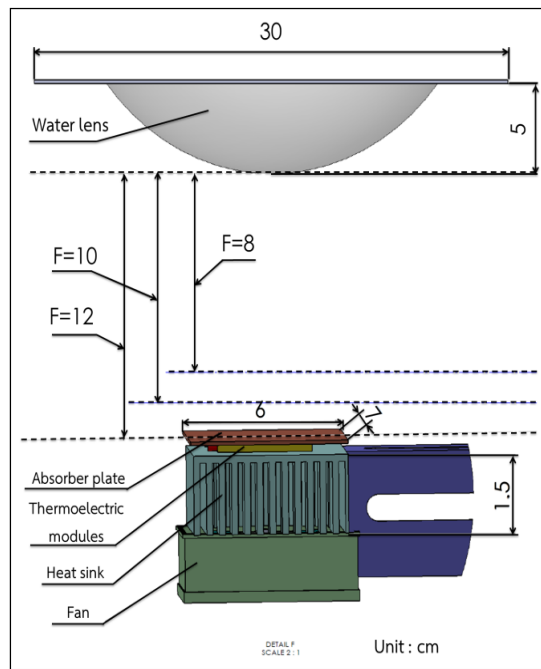

Fig. 1 Schematic view of the TE solar collector with water lens concentrator

The water lens was mounted on the one-axis tracking system. Tracking of the sun was done manually. The TE solar collector was mounted on the horizontal fixed base as shown in Fig. 2.

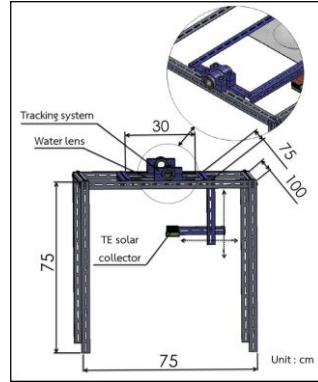

Fig. 2 Experimental set up of the TE solar collector with water lens concentrator

The collector was instrumented with T-type (accuracy  $\pm 0.5^\circ\text{C}$ ) thermocouples for the flowing air, the surface of absorber plate and the heat sink. Three pyranometers (Kipp & Zonen model CM 11 accuracy  $\pm 10 \text{ W/m}^2$ ) were used to measure the incident solar radiation on the fixed system, focus plan and tracking system. The air flow rate was calculated from the air velocity, measured by a hot wire anemometer (Testo model 445, accuracy  $\pm 0.03 \text{ m/s}$ ). The output current and voltage were measured with a multi-meter (Fluke model 189, accuracy VDC  $\pm 0.025\%$ , A  $\pm 0.5\%$ ). This study varied the length of focus (Distance between the water lens and absorber plate) in three lengths namely: 8, 10 and 12 cm. Experimentation started at 9 a.m. and ended at 4 p.m.

### Analysis

Concentration ratio of the water lens

The concentration ration ( $C$ ) is given by

$$C = \frac{G_r}{G_a} \quad (1)$$

where  $G_r$  is the solar energy flux on the receiver (absorber)

$G_a$  is the solar energy flux on the aperture area

### TE power generation

The electrical output of the TE solar collector ( $P$ ) is calculated from the measured data as follows:

$$P = I \cdot V \quad (2)$$

where  $I$  is the current of the TE modules.  $V$  is the voltage of the TE modules.

Vorobiev et al. (2006) suggested that the conversion efficiency ( $\eta_e$ ) is as follows:

$$\eta_e = \eta_c \frac{M - I}{M + \frac{T_c}{T_h}} \quad (3)$$

where  $M = \sqrt{I + ZT_m}$  which  $T_m = 0.5(T_h + T_c)$

$T_h$  and  $T_c$  are the hot and cold side temperatures of TE module, respectively.

$T_m$  is the average temperature

$Z$  is the figure of merit of the TE material ( $Z = 1.6 \times 10^{-3} \text{ 1/K}$ )<sup>11</sup>

$\eta_c$  is the Carnot efficiency;  $\eta_c = \frac{T_h - T_c}{T_h}$

Note that  $ZT_m$  is a characteristic parameter of the thermoelectric element and essentially governs its internal conversion efficiency. It is well known that the value of  $Z$  can have strong variations in temperature. In this study, in order to gain insight into the optimal collector operating temperatures, the value of  $Z$  was assumed to be constant. Although this may be an over simplification of the actual situation, it provides tractable solutions for the solar collector temperature and operating efficiency of the thermoelectric element.

## RESULTS

Fig. 3 shows the effect of varying the length of focus on the concentration ratio and diameter of the focus area. Tests were conducted at three different lengths of focus: 8, 10 and 12 cm. The concentration ratio increases as length of focus increases and varies between 3.4 and 7.8. However, the diameter of focus area decreases significantly as the length of focus increases.

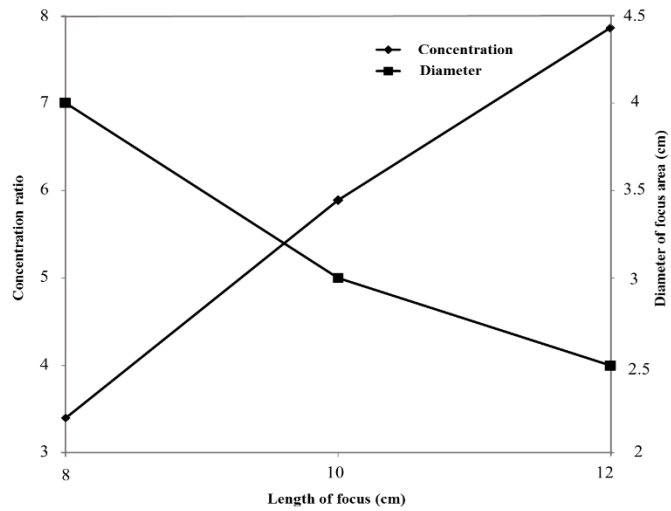

Fig. 3 Effect of the focus length on concentration ratio and diameter of focus area (Solar radiation on horizontal plane =  $850 \text{ W/m}^2$ )

The effect of the length of focus on the hot and cold sides of TE modules is shown in Fig. 4. The hot side temperature increases as the length of focus increases and varies between  $54.2$  to  $64.3^\circ\text{C}$ . Meanwhile, the cold side temperature increases slightly. Consequently, the temperature difference between the hot and cold sides of TE modules increases linearly with the focus length.

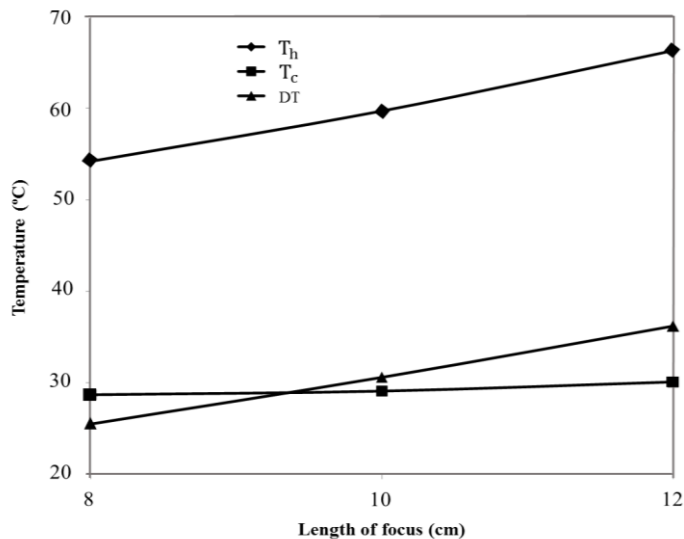

Fig. 4 Effect of the focus length on hot and cold sides temperature of TE modules (Solar radiation on horizontal plane =  $850 \text{ W/m}^2$ )

Fig. 5 presents the output power and conversion efficiency, as a focus length. It is apparent that the power and efficiency continued to increase as the focus length increased. This is due to the increasing temperature difference between the hot and cold sides of TE modules as shown in Fig. 4. The maximum power and conversion efficiency are  $7 \times 10^{-3}$  W and 1.15%, respectively at a temperature difference of  $36.2^\circ\text{C}$ . The open-circuit voltage and the short-circuit current are 0.09 V and 77.7 mA, respectively.

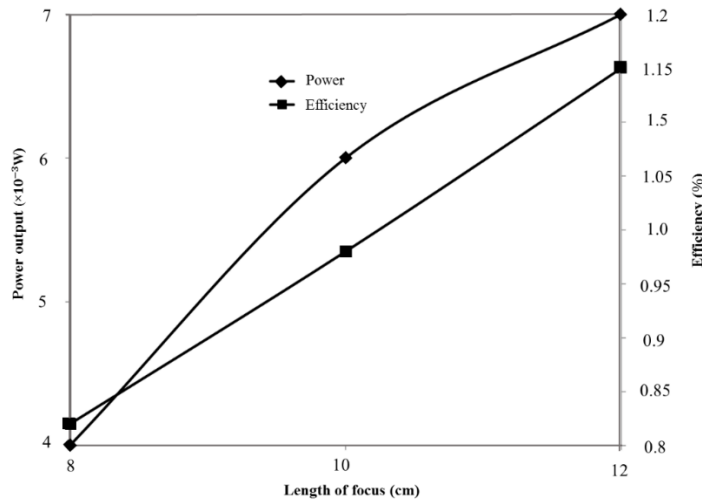

Fig. 5 Effect of the focus length on power output and conversion efficiency of TE modules (Solar radiation on horizontal plane =  $850 \text{ W/m}^2$ )

The hot side temperature and electrical output of the TE solar collector with and without water lens are presented in Table 1.

Table 1 Hourly variation of climatic conditions, hot side temperature and power output of the TE solar collector with and without water lens (5 January 2014)

Time (hr)	Solar radiation ( $\text{W/m}^2$ )	Ambient temperature ( $^\circ\text{C}$ )	Hot side temperature ( $^\circ\text{C}$ )		Power output ( $\times 10^{-3}$ W)	
			With water lens	Without water lens	With water lens	Without water lens
9	485	18.6	58.6	32	6	1.9
10	687	20.9	59.2	35	6.2	2.1
11	747	22.7	60.3	40	6.3	2.4
12	800	24.6	63	42	6.6	2.5
13	850	26	66.3	49	7	3
14	680	26.3	64	45	6.7	2.7
15	500	26.1	62	41	6.5	2.5
16	450	25	60	39	6.3	2.3

Table 1 presents a comparison of the hot side temperature and electrical power output. The hot side temperature of the TE solar collector with water lens was higher than that TE solar collector without water lens by 35% at the maximum solar radiation of 850 W/m<sup>2</sup>. Meanwhile, the power output was also higher than that of the TE solar collector without water lens. It also has been experimentally proven that the electrical power the TE solar collector can be improved up to 57% by using a water lens.

## ACKNOWLEDGEMENTS

The authors would like to express their appreciation to Prof. Dr. Ryosuke O. Suzuki from Hokkaido University, Japan for providing the TE modules.

## CONCLUSIONS

The experimental study on operation performances of the TE solar collector with water lens was conducted. Under the test conditions used here, the most suitable operating condition was with a focus length of 12 cm. The maximum power and conversion efficiency are  $7 \times 10^{-3}$  W and 1.15%, respectively at a temperature difference of 36.2°C. The TE solar collector with water lens produced a power output higher than the TE solar collector without water lens by 57%. Therefore, the experimental results indicate that the water lens creates a positive effect for increasing the electrical power output for the TE solar collector.

## REFERENCES

- Fan H., Singh, R. and Akbarzadeh A. (2011). Electric power generator from thermoelectric cells using a solar dish concentrator. *Journal of Electronic Materials* 40, 1311-1320.
- Lertsatitthanakorn C., Rungsiyopas M., Theryothin A. and Soponronnarit S. (2012). Performance study of a double-pass thermoelectric solar air collector with flat plate reflectors, *Journal of Electronic Materials*, 41, Issue 6, 999-1003.
- Min, G. and Rowe, D.M. (2002). Symbiotic application of thermoelectric conversion for fluid preheating/power generation. *Energy Conversion and Management* 43, 221-228.
- Qiu, K. and Hayden, A.C.S. (2011). Development of thermoelectric self-powered heating equipment. *Journal Electronic Materials* 40, 606-610.
- Rinalde, G.F., Juanico, L.E., Tagliavore, E., Gortari, S. and Molina, M.G. (2010). Development of thermoelectric generators for electrification of isolated rural homes. *International Journal of Hydrogen Energy* 35, 5818-5822.
- Rowe, D.M. (1999). Thermoelectric, an environmentally-friendly source of electrical power. *Renewable Energy* 16, 1251-1256.
- Vorobiev, Y., Gonzalez-Hernandez, J., Vorobiev, P. and Bulat, L. (2006). Thermal-photovoltaic solar hybrid system for efficient solar energy conversion. *Solar Energy* 80, 170-176.
- Zhu, J., Gao, J., Chen, M., Zhang, J., Du, Q., Rosendahl, L.A. and Suzuki, R.O. (2011). Experimental study of a thermoelectric generation system. *Journal of Electronic Materials* 40, 744-752.